

JUST LIFT



JL 250 Compact crane

Motorized tillerhead

Arm controls with Remote control

Lift and extension with hydraulic system

Standard Anti-tipping system

100% electric

JL 250



👁 Front



👁 Side



👁 Top



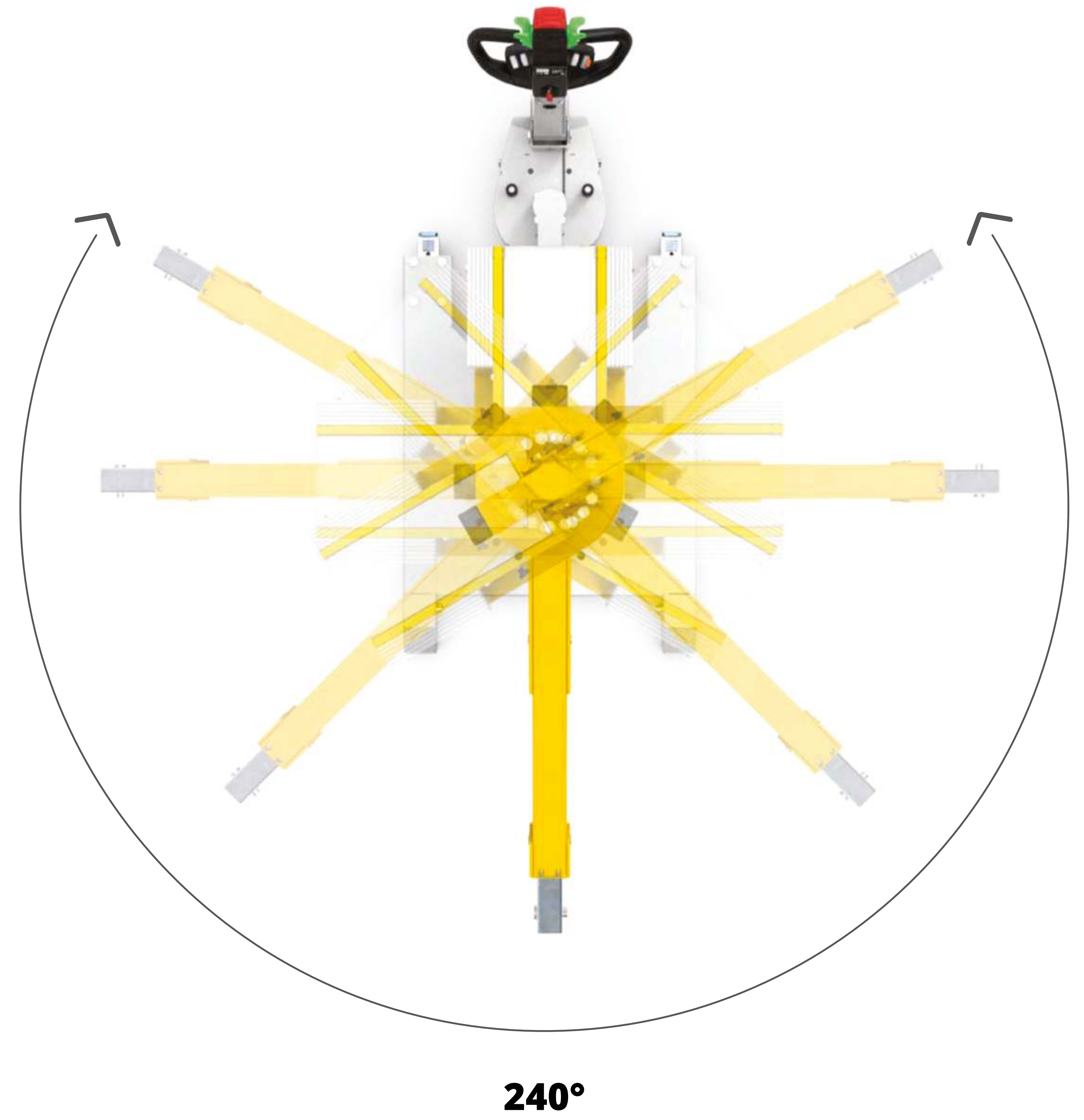
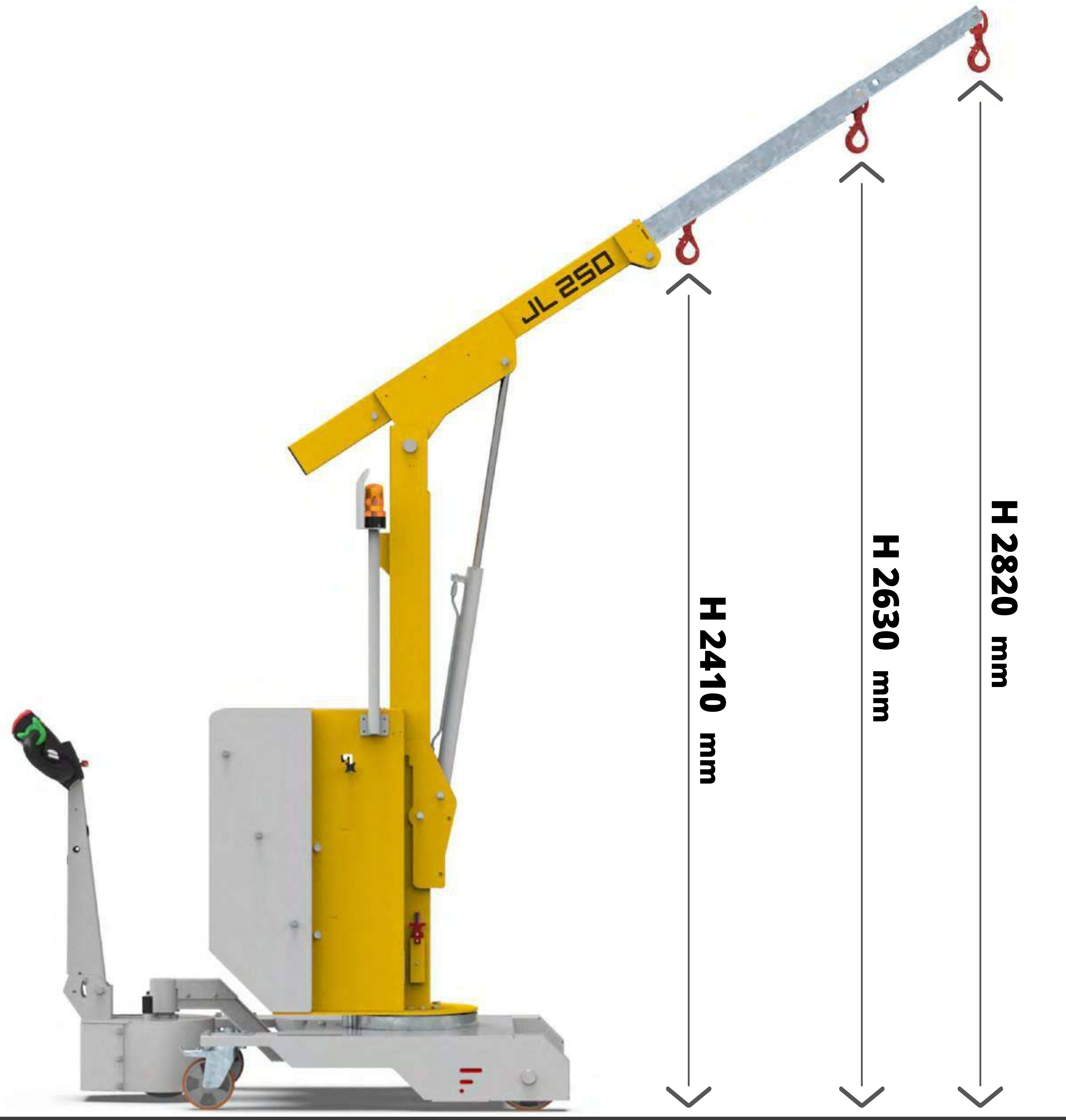

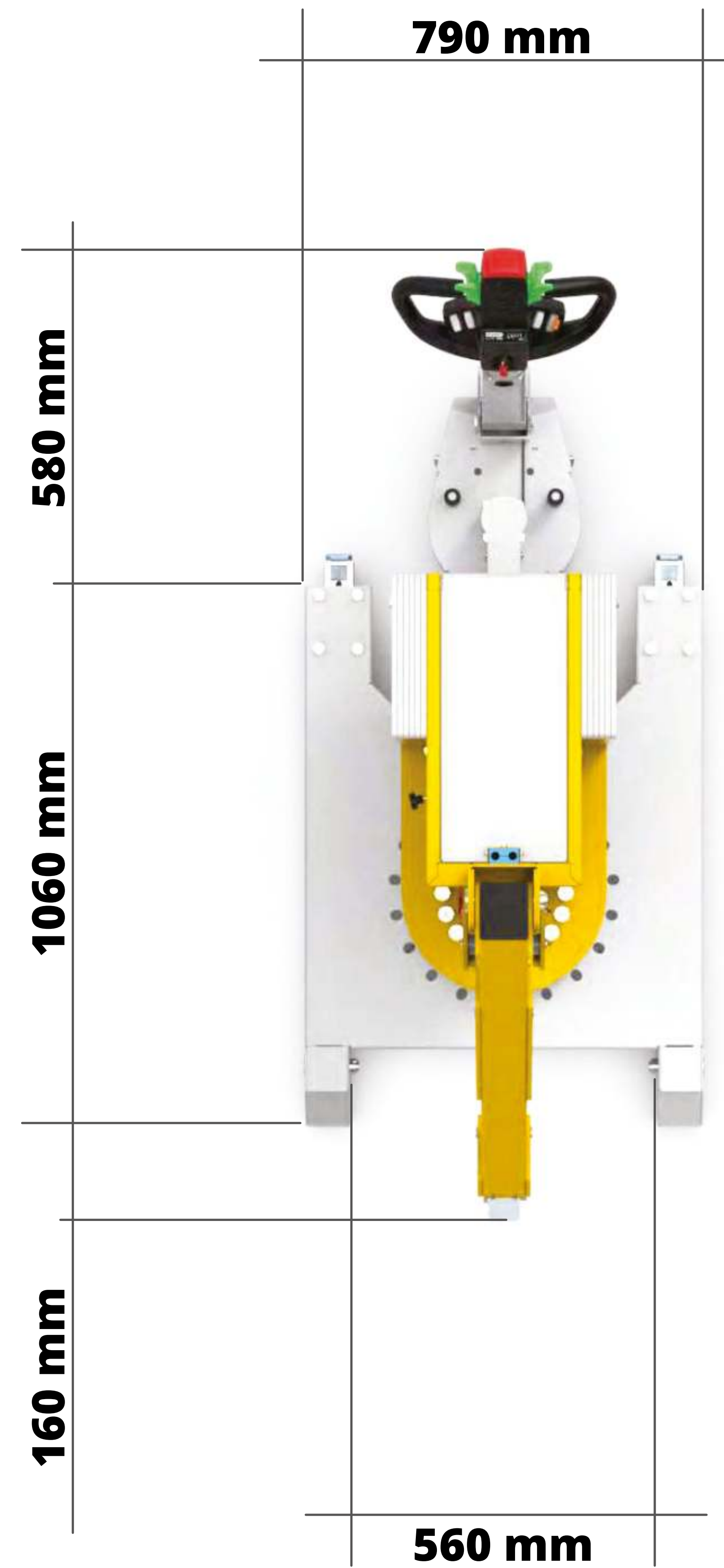
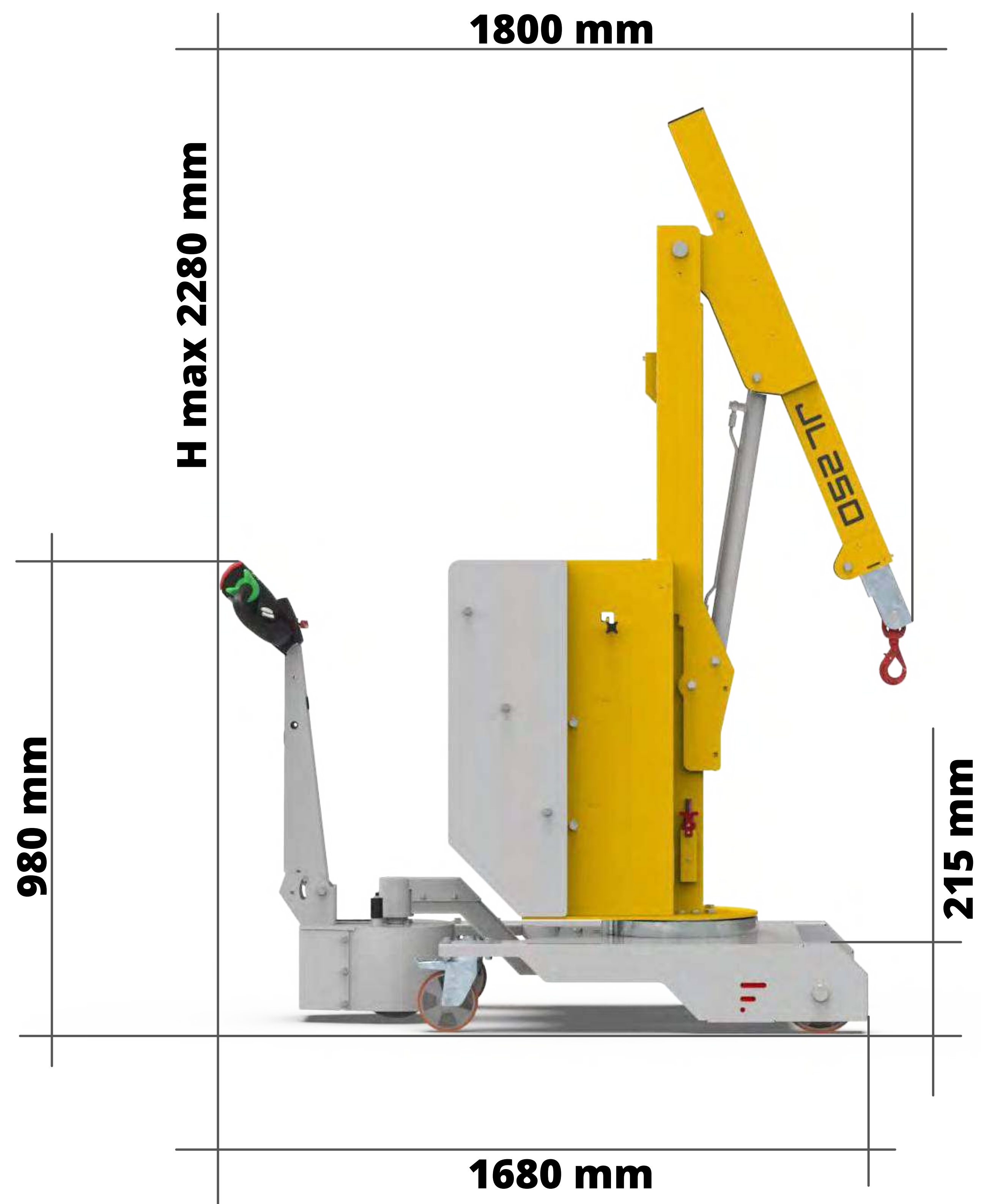

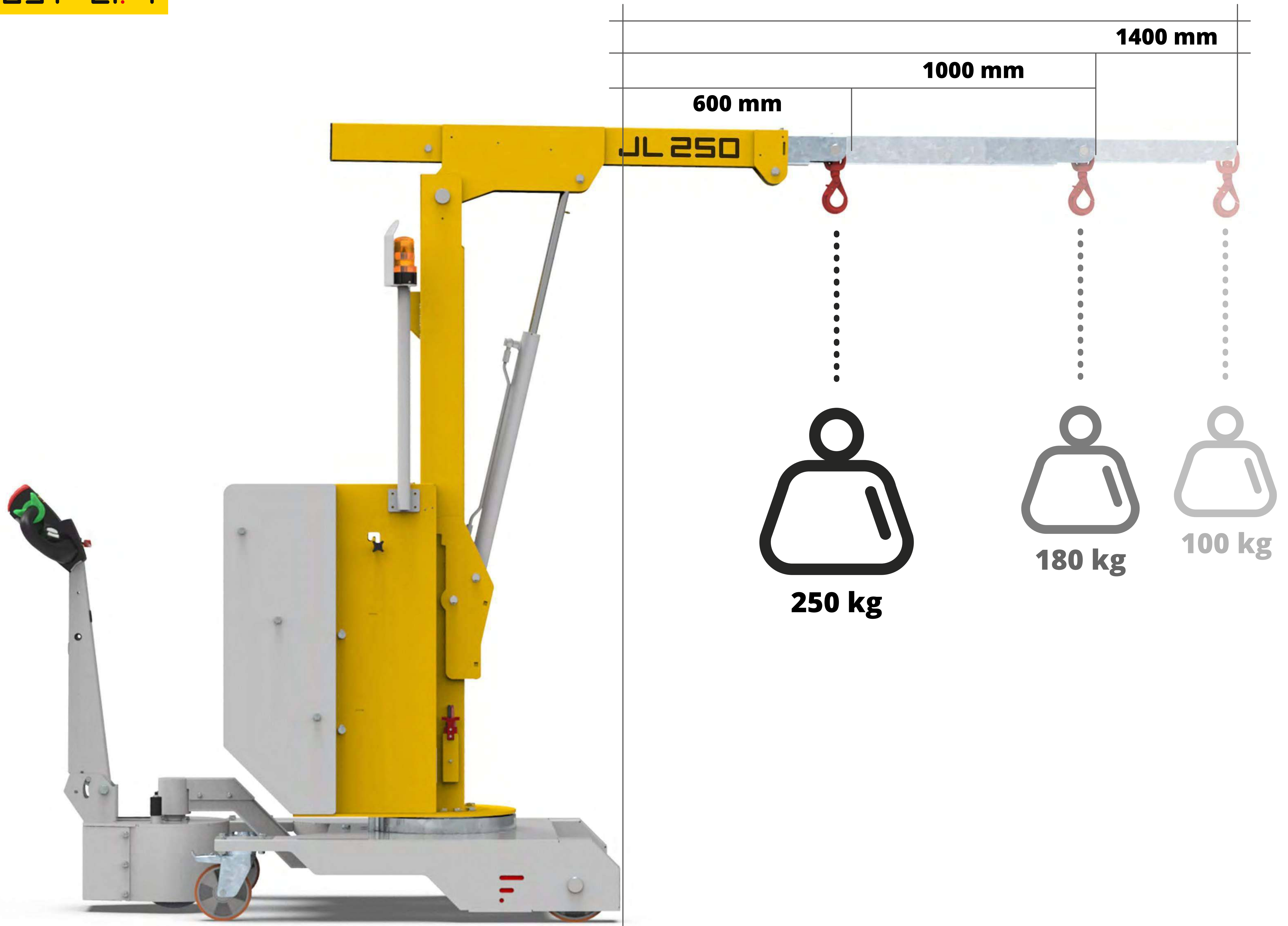



Ergonomic driving

*Fitted as standard

The tillerhead has been designed and built to make the operator's use more ergonomic by ensuring the right comfort on long use during the work shift.

Its ergonomic design allows you to have all the control buttons at your fingertips, the display indicates the remaining battery charge and the key is situated on the top of the tiller.

The structure is made with a strong plastic cover to resist in case of accidental impacts.

5 speed Kit

*Fitted as standard

On the latest version of the tiller handle installed on model JL250 a 5 speed button is a standard feature. By pressing it, with each click, the speed switches from one gear to another.. In this way the operator can select the appropriate speed very quickly depending on the type of maneuvers is making. The *Flex to Go system* has been designed to assure a greater maneuverability in tight and driving the unit at an higher speed when a longer distance has to be covered.

Each click adds 20% more speed than the previous gear. Speed ramp: 20% - 40% - 60% - 80% - 100%

Once in fifth gear, pressing the button returns to first gear.



5 SPEED CONTROL

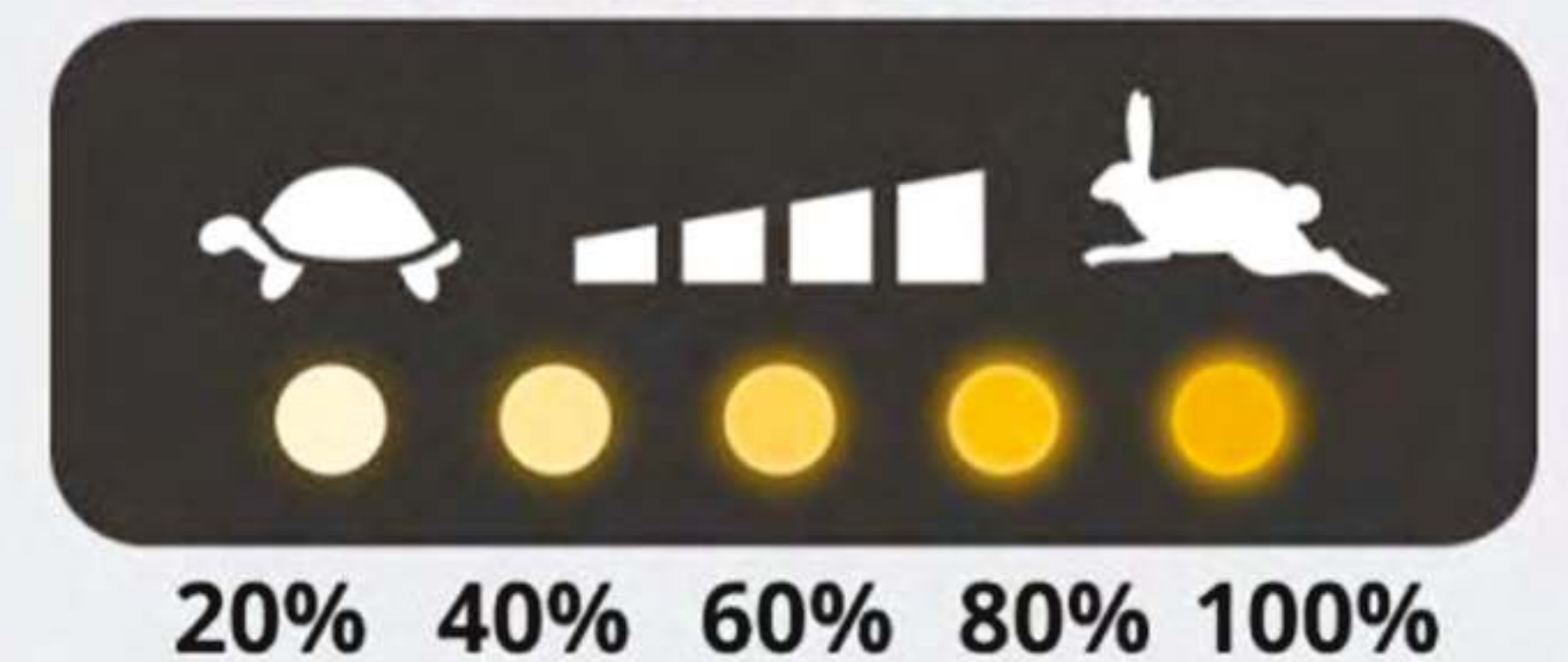

Wire control

*Fitted as standard

The wire control allows you to lift the load with one hand and maneuver it to the correct position with the other hand.

2 Lifting and downing speeds: the remote control buttons have a double click for select the speed of the arm.

Its ergonomic design allows you to work many hours without tiring your hand.

The structure is shock resistant in case of falls of less than one meter from the ground.

The push-button panel allows the 4 movements of the arm, the horn and the emergency stop in case of need.





Remote control

*Optiona to add

With the remote control it's easier and more comfortable to maneuver the load to be lifted. It allows you not to have cables that hinder the operations of moving and lifting things.

2 Lifting and downing speeds: the remote control buttons have a double click for select the speed of the arm.

Its ergonomic design allows you to work many hours without tiring your hand; the structure is shock resistant in case of falls of less than one meter from the ground.

The push-button panel allows the 4 movements of the arm, the horn and the emergency stop in case of need.

The battery has an autonomy of about 12 hours and is rechargeable with the special case provided by Just Lift.



JUST LIFT

Just Lift srl - Via Palazzina 1, Sarcedo
36030 (VI) - Italia

Contacts:

sales@just-lift.com
+39 0445 366785

Web site:

www.just-lift.com

