

MasterMover®

Central Europe Electric Tug Solutions



SM100

Smart Mover®

**Battery Powered Tug |
SmartMover® SM100**

The SM100 is a battery powered tug that generates traction through a leveraged weight transfer system. A portion of the load weight is used to apply pressure on the optimally-sized wheels, allowing a single operator to easily move loads weighing up to 1,000 kg. A simple lever ensures a secure coupling to the load making the SM100 a safer alternative to manual handling of heavy wheeled loads, even on slopes or in congested areas.

Industries

Suitable for use in a wide range of applications and sectors



Key Benefits

1 year full guarantee

- Battery monitoring system
- FEA tested steel chassis
- All steel covers
- 2 Drive motors
- Secure coupling
- Leveraged weight transfer

Product Dimensions

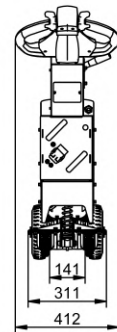
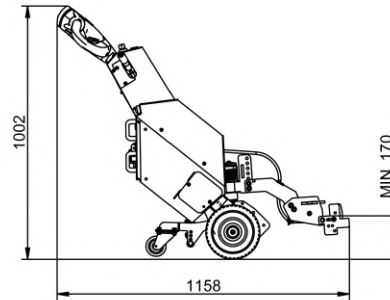
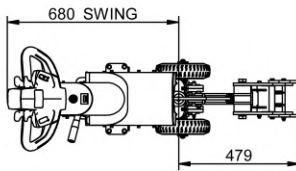

Safety Features

See our website for full technical details



Anti-crush button



Warning horn



Support wheels for operator safety

Max Load Weight

See our website for full technical details



Castors

Up to 1,000 kg*



Rails

Up to 4,000 kg*

*"Maximum load weight" is only a recommendation that we arrive at by estimating rolling resistance. Your environment and wheel type may affect this figure which is why we carry out a detailed technical evaluation on every project. All of our calculations include a "safe work load" factor to ensure safe operation in all circumstances.

Identification

Product code	SM100
Recommended load weight - Castors	1000 kg
Recommended load weight - Rails	4000 kg
Machine weight including battery	70 kg
Drive type	Electric DC
Parking brake	Electromagnetic
Drive wheel type	Puncture-proof, non-marking
Drive motor power	2 x 0.22 kW
Controller type	110 DC Permanent
Variable machine speed	0.1 km/h - 5 km/h
Ingress Protection	IP44

Battery options

Battery pack - sealed - 22Ah 24V - interchangeable

Charging options

Charger - external - 5A 24V - 85V-265V

Additional equipment

Option - forward facing LED

Option - roll cage pivot link bar - universal

Option - XrissXcross roll cage connection straps

Option - flashing safety light and motion bleeper

Male coupling options

Coupling - manual - multi size

Female coupling options

Coupling - adaptor - 50mm x 25mm - straight

Coupling - adaptor - 50mm x 25mm - angled

Coupling - adaptor - waste bin A frame

Contact Us

Find your local dealer here

To arrange a demonstration, or for further information about our electric tug material handling solutions, please contact us

K AMP 2025/2b, 664 34 Kuřim, Czech Republic

Telephone Sales: +420 721 187 768 **Email:** petr.cermak@smartsels.com

Website: www.mastermover.com



About Us

Located in Derbyshire, the UK's manufacturing hub, MasterMover is a British business success story with customers all over the world.

Our products are relied upon by market leading organisations and global brands across a broad cross-section of industries including Aerospace, Automotive, Pharmaceutical, Retail and Healthcare.

