

ATT400+



Features & Benefits

ATT400+



ATT400+

ATT400+

ATT400+ is the most effective electric load mover to pull and push wheeled loads.

Battery



- Interchangeable
- Maintenance-free
- Battery monitoring system

Strong

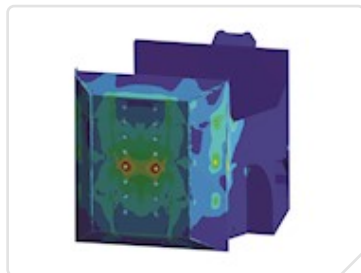

- FEA tested steel chassis
- Impact resistant headset
- Steel couplings

Powerful

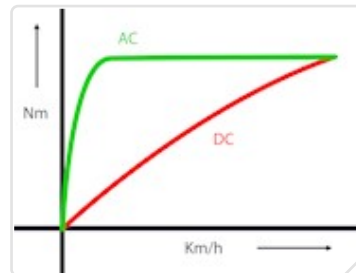

- AC drive motor
- Up to 5,000 kg load capacity
- High-torque gearbox

Safety



- Self-levelling support castor
- Two speed selector switch
- Emergency stop button

Traction

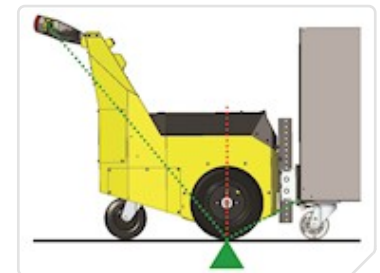

- Leveraged weight transfer
- Controlled start acceleration
- Industrial pneumatic drive wheels

Identification

Recommended load weight- Castors	5000 kg
Recommended load weight- Rails	40000 kg
Machine weight including battery	365 kg
Drive type	Electric AC
Drive wheel type	Rubber - pneumatic
Parking brake	Electromagnetic
Variable machine speed	0.1 km/h - 5 km/h
IP rating for the machine	IP44

Battery options

Battery pack - sealed - 119Ah 24V - fixed

Charging option

Charger - external - 15A 24V - 85V-265V

Optional extras

Option - two speed selector switch

Male coupling

Coupling - male - height adjustable box

Female coupling

Coupling - female - box

Coupling options

ATT400+

Z41-00602

Coupling - male - height adjustable box

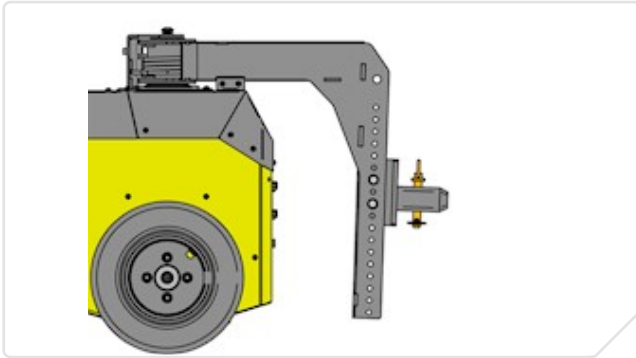

Z41-00701

Coupling - female - box



Machine options

ATT400+

Z41-00500

Option - wireless control handset



Z41-00501

Option - flashing safety light and motion bleeper



Z41-00502

Option - wheel protectors



Z41-00505

Option - two speed selector switch



Find out **more**

Contact us today to find out which electric tug from MasterMover can help to improve efficiency and safety in your workplace.

For sales and support please contact:

SELS s.r.o.

K AMP 2025/2b
66434, Kuřim, Czech Republic

T +420 721 187 768

E petr.cermak@smartsels.com

W www.smartsels.com